

YS / SR

Elastomer Wheel Caster

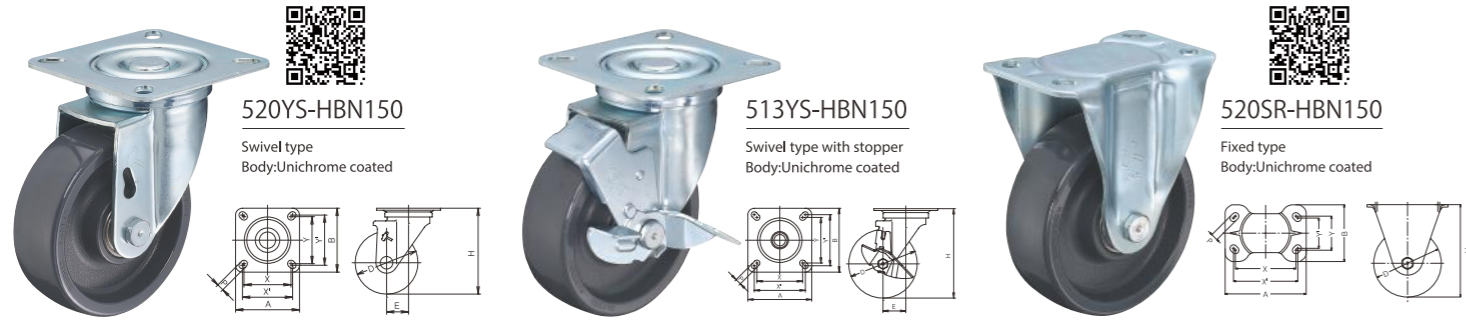

●Using heat-treated steel, the body is not only light but also robust and has extended the service life.



Product Code			Load Capacity 1pc(daN)	Wheel Composition	Overall Height Hmm	Top Plate A×B mm	Fitting Pitch X×Y mm (X'×Y') mm	Fastening hole dia. Pmm	Tread width mm
Model No.	Wheel	Size (mm)							
520 YS	- HBN	100	180	Solid Elastomer Wheel with Ball bearing	137	102×102	75×75 (80×80)	11	40
520 SR					137	140×94	100×56 (112×50)	11	40
520 YS 513 YS	- HBN	150	250	Solid Elastomer Wheel with Ball bearing	196	140×140	100×100 (112×112)	13	50
520 SR					196	150×105	112×63 (119×56)	13	50

※Stopper type is only available with 150mm wheel.

BPS / BPR

Elastomer Wheel Caster

●The body is manufactured by welding very thick steel materials to achieve high durability and high load capacity.



Product Code			Load Capacity 1pc(daN)	Wheel Composition	Overall Height Hmm	Top Plate A×B mm	Fitting Pitch X×Y mm (X'×Y') mm	Fastening hole dia. Pmm	Tread width mm
Model No.	Wheel	Size (mm)							
500 BPS 519 BPS 500 BPR	- HBN	150	250	Solid Elastomer Wheel with Ball bearing	187	114×102	80×76 (88×64)	13	50

※Please consult our sales office for details.

A Starting Difference



HBN

Light handling & Smooth traveling
Elastomer Wheel



●Manufacturing Factory
Headquarters factory
4-7-35, Nishi-Iwata, Higashi-Osaka, Osaka 578-0947 Japan
Hirakata factory
3-2-1, Shodaidajika, Hirakata, Osaka 573-1132 Japan

HAMMER CASTER SALES

●Hammer Caster Sales Co., Ltd. (as Sales company)
Tokyo Branch
6-5-4, Shimbashi, Minato-ku, Tokyo 105-0004 Japan
Osaka Branch
1-2-6, Aramoto, Higashi-Osaka, Osaka 577-0023 Japan

■Please feel free to ask for any caster consultancy.
E-mail : info@hammer-caster.co.jp
Web : www.hammer-caster.com

■Click and follow our official SNS accounts.
www.facebook.com/hammercasterofficial/

www.instagram.com/hammer_caster_official/

Copyright © 2024 Hammer Caster Co., Ltd. All Rights Reserved.

Labor saving by stress-free handling.



HBN

Solid Elastomer Wheel with Ball bearing

CHECK!!

Product movie 「Smooth and light start. HBN wheel」



The special elastomer wheel gives excellent starting and swiveling performance. The service life is extended by heat treated steel body.

Wheel Characteristics

- Excellently resistant to cutting oil and chemical.*1
- No floor marking at jump start or sudden stop.
- Installed ball bearing at wheel bore, increased durability.
- Battery saving for AGV by light driving force.*2



*1 Please consult our sales offices for the anti-chemical property in detail.
 *2 Please specify "Bolt Lock type" when installing to AGV for safety.

■ Wheel comparison in tractive force between RB(rubber) and HBN(special elastomer)

520S-RB150

520YS-HBN150

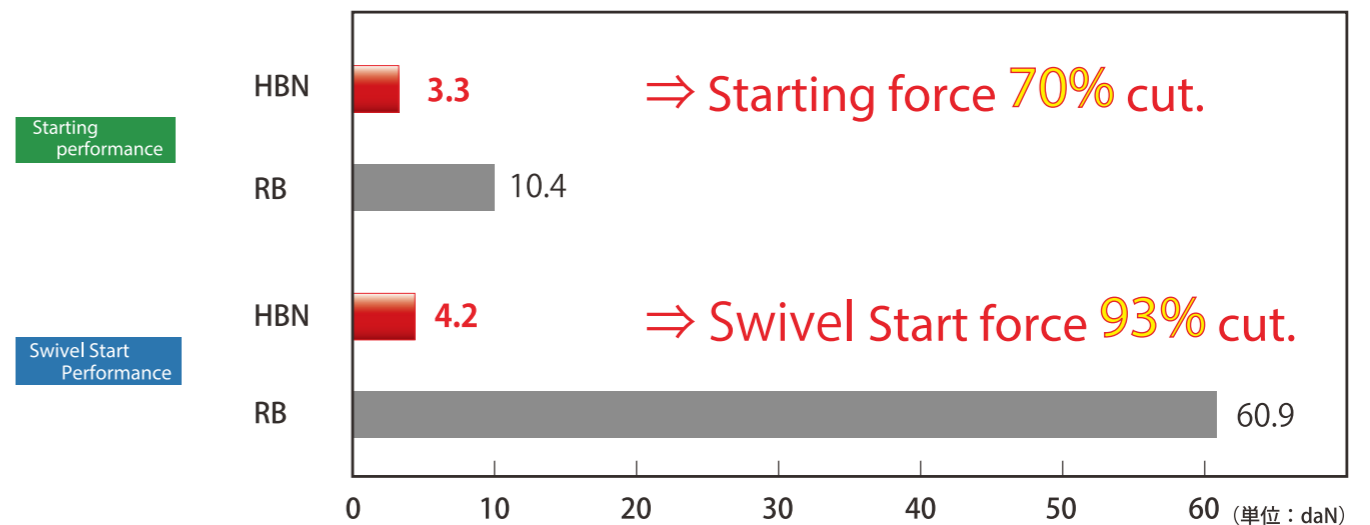
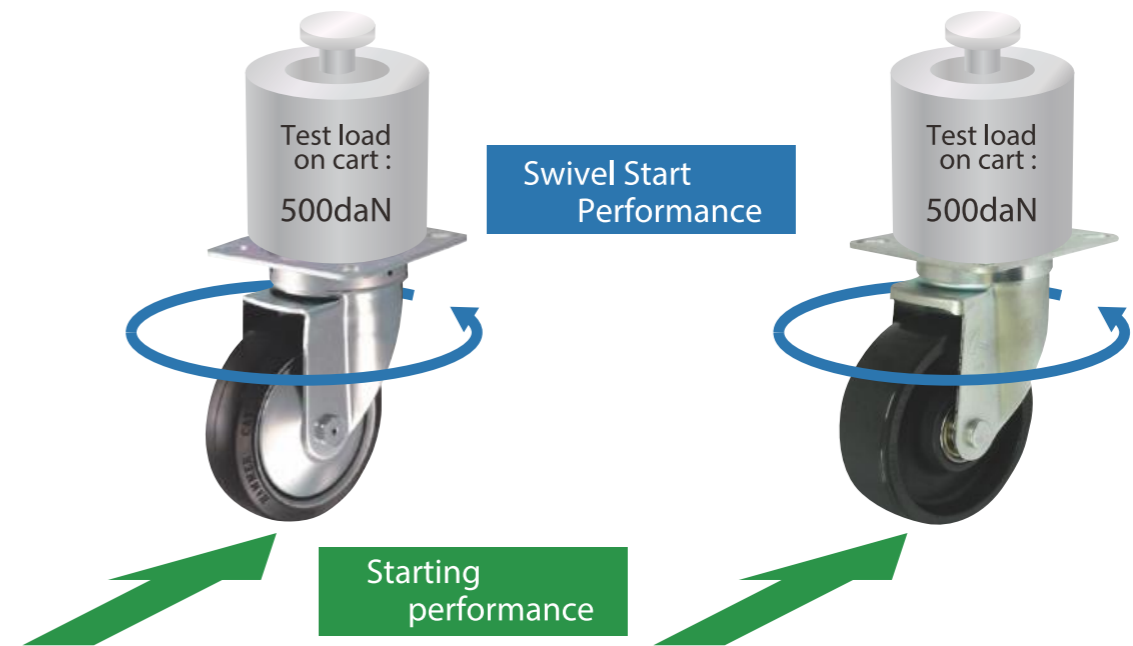

■ What is "Elastomer (TPE)" ?



Elastomer material combines the superior properties of elastic rubber and plastics, which is easy to mold and recycle, and are expected to play an active role in a wide range of industrial fields.