

Product Lineup

Expander Plug Caster

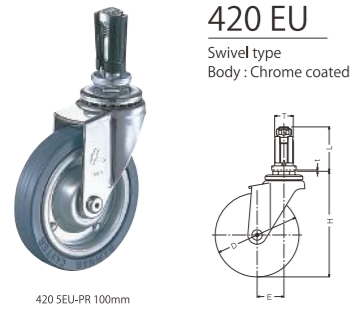

Product code				Load Capacity 1pc(daN)	Wheel composition	Overall height H mm	Offset E mm	Swivel radius mm
Series	Plug No.	Model	Wheel Size (mm)					
420 415	□	EU EX EN	- R	40	Rubber wheel with plastic bush	60	20.0	41
				50	30	68	21.0	47
				65	30	85	24.0	58
				75	40	95	29.0	68
				85	50	107	28.0	72
				100	50	126	32.0	83
				125	60	152	39.0	103
				150	60	180	42.0	118

The turning radius is a value without a stopper. For more details, please refer to the digital catalog from the QR code below.

EU series



Plug No.	Inner dia. of pipe (mm)	Wheel size (mm)
1	16 ~ 18	40 ~ 75
2	19 ~ 21	
3	22 ~ 24	
4	18 ~ 20	85 ~ 150
5	21 ~ 23	
6	24 ~ 26	

EX series



Plug No.	Inner dia. of pipe (mm)	Wheel size (mm)	
		40 ~ 75	85 ~ 150
1	16	○	-
2	18	○	-
3	19	○	○
5	21	○	○
6	22	○	○
8	24	○	○

EN series



Plug No.	Outer dia. of pipe (mm)	Wheel size (mm)
1	Φ32	40 ~ 150
2	Φ38	
3	Φ25	
4	□25	
5	□32	

Please specify the plug number and type for ordering.

Series	Plug No.	Model	Wheel	Size
例: 420	3	EU	- R	75

Wheels

Wheel selection is available from various material such as rubber, Nylon, Urethan, etc... Please pick one on your demand.



*Please consult our sales office for details.

Fit the pipes, Everywhere. Expanding Stem Caster

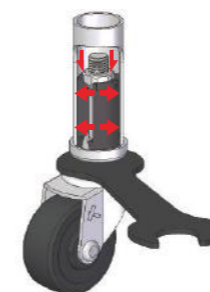

Flexible pipe-fitting lineups of
EU/EX/EN stems provide
a diverse caster solution on demand.



● Manufacturing Factory
Headquarters factory
4-7-35, Nishi-Iwata, Higashi-Osaka, Osaka 578-0947 Japan
Hirakata factory
3-2-1, Shodaidajika, Hirakata, Osaka 573-1132 Japan



● Hammer Caster Sales Co., Ltd. (as Sales company)
Tokyo Branch
6-5-4, Shimbashi, Minato-ku, Tokyo 105-0004 Japan
Osaka Branch
10-35, Shinjo-Nishi, Higashi-Osaka, Osaka 578-0964 Japan

Please feel free to ask for any caster consultancy.
E-mail : info@hammer-caster.co.jp
Web : www.hammer-caster.com

Click and follow our official SNS accounts.
www.facebook.com/hammercasterofficial/

www.instagram.com/hammer_caster_official/

Copyright © 2018 Hammer Caster Co., Ltd. All Rights Reserved.

Flexible caster fitting makes unique design possible.

Plug types EU / EX / EN covers various kinds of pipes.

What is Expander Plug caster?

- When producing carts and racks using pipes, it is possible to attach them directly to the pipe, eliminating the need for processing of the receiving end of the pipe.

STEP 1 Insert firmly into the pipe.

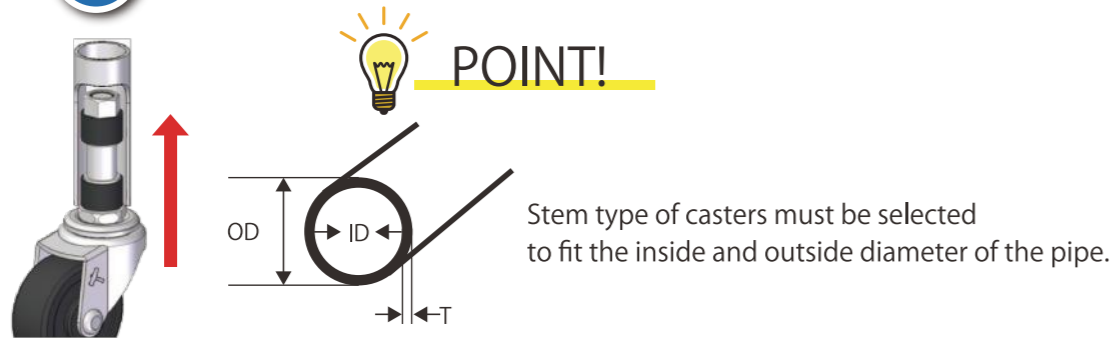

STEP 2 Tighten with a spanner and complete.



Comparison of work efficiency between expander plugs and other fittings.

- The expander plug type can be easily attached directly to the pipe. It helps not only reducing design waste, but also improving work efficiency.

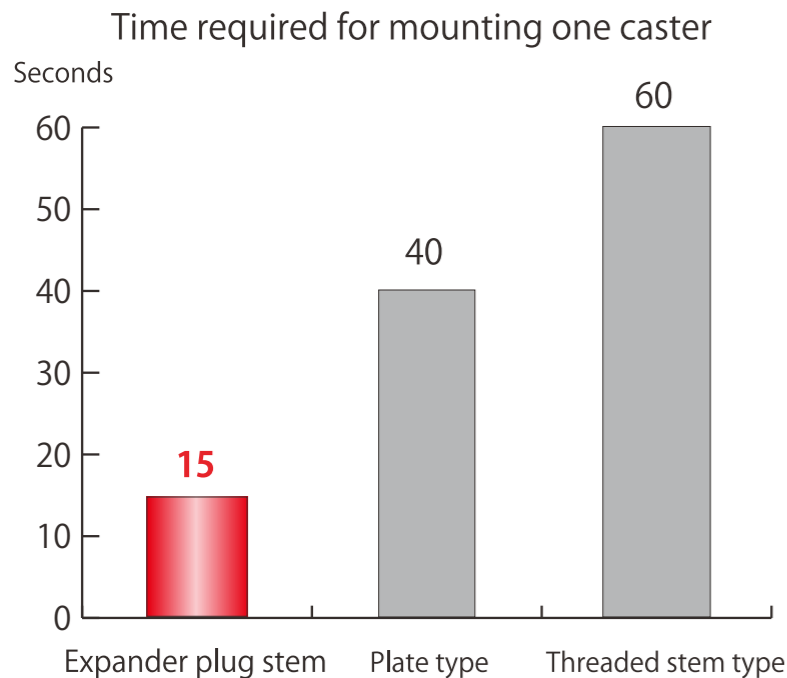

Work time cut up to **1/4**
* Approximately

If fitting casters to 100 carts,
Expander plug stem requires 100 minutes.
Plate type requires 260 minutes.
Threaded stem type 400 minutes.

Thus saving up to 5 hours in total !!

Capable to fit into various pipes

EU stem type

- EU plug code varies with the inner diameter of the pipe to be installed.
- It can be used in a wide range of pipes.
- EU plug is made of Nylon, so please be careful when using it in a water-absorbing environment.

EU stem type for 40mm~75mm wheel (M10 stem)

EU Code	Description	Fitting range	Outer dia.	Pipe thickne
1	16-18 (1EU)	Φ16~Φ18	3/4" (19.1Φ)	1.0~1.5t
2	19-21 (2EU)	Φ19~Φ21	7/8" (22.2Φ)	1.0~1.6t
3	22-24 (3EU)	Φ22~Φ24	1" (25.4Φ)	1.0~1.6t

EU stem type for 85mm~150mm wheel (M12 stem)

EU Code	Description	Fitting range	Outer dia.	Pipe thickne
4	18-20 (4EU)	Φ18~Φ20	7/8" (22.2Φ)	1.2~2.0t
5	21-23 (5EU)	Φ21~Φ23	1" (25.4Φ)	1.2~2.0t
6	24-26 (6EU)	Φ24~Φ26	1 1/8" (28.6Φ)	1.2~2.0t

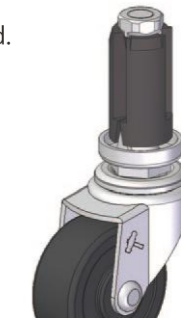

Product Image

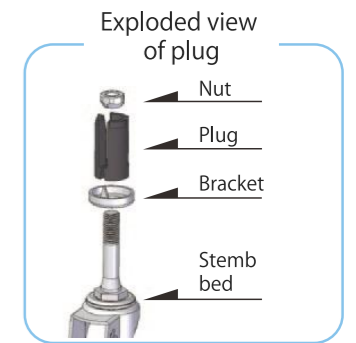

EX stem type

- It can be installed regardless of the thickness of the pipe.
- EX plug is made of rubber, thus it adheres to the inner surface of the pipe and firmly fixes the casters.

EX stem type

EX code	Stem dia. (Rubber plug outer dia.)
1	Φ16
2	Φ18
3	Φ19
5	Φ21
6	Φ22
8	Φ24



Product Image

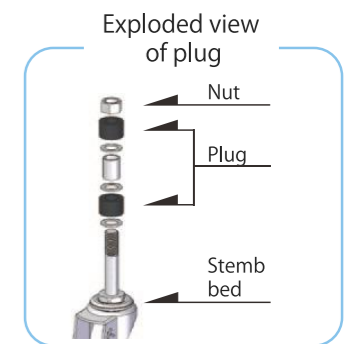

EN stem type

- Capable to fit into square pipes.
- EN plug is made of Nylon, so please be careful when using it in a water-absorbing environment.

EN stem type for round tubes

EN code	Description	Pipe outer dia.	Bracket thickness	Pipe thickness
1	Φ32 (1EN)	Φ32	2.3	Applicable up to pipe thickness t=1.8mm.
2	Φ38 (2EN)	Φ38	2.3	
3	Φ25 (3EN)	Φ25	1.6	

EN stem type for square tubes

EN code	Description	Pipe outer dia.	Bracket thickness	Pipe thickness
4	25□ (4EN)	25□	1.6	Applicable up to pipe thickness t=1.8mm.
5	32□ (5EN)	32□	1.6	



Product Image

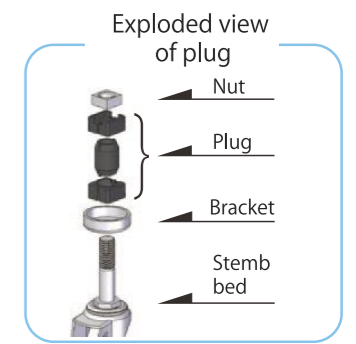

Sus All stainless caster
Some models are available with stainless steel body. Please consult our sales office for details.