

YS / SR

Elastomer Wheel Caster

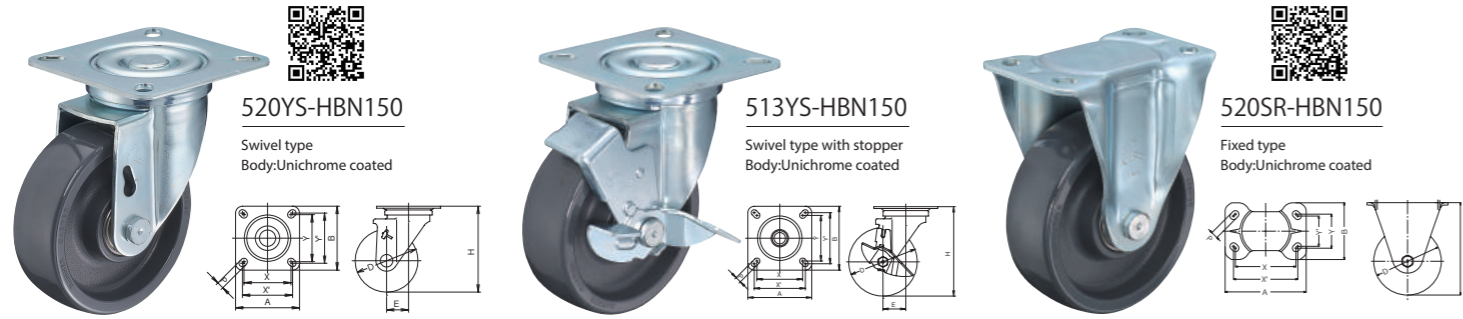

●Using heat-treated steel, the body is not only light but also robust and has extended the service life.



Product Code			Load Capacity 1pc(daN)	Wheel Composition	Overall Height Hmm	Top Plate A×B mm	Fitting Pitch X×Y mm (X'×Y') mm	Fastening hole dia. Pmm	Tread width mm
Model No.	Wheel	Size (mm)							
520 YS	- HBN	100	180	Solid Elastomer Wheel with Ball bearing	137	102×102	75×75 (80×80)	11	40
520 SR					137	140×94	100×56 (112×50)	11	40
520 YS 513 YS	- HBN	150	250	Solid Elastomer Wheel with Ball bearing	196	140×140	100×100 (112×112)	13	50
520 SR					196	150×105	112×63 (119×56)	13	50

※Stopper type is only available with 150mm wheel.

BPS / BPR

Elastomer Wheel Caster

●The body is manufactured by welding very thick steel materials to achieve high durability and high load capacity.

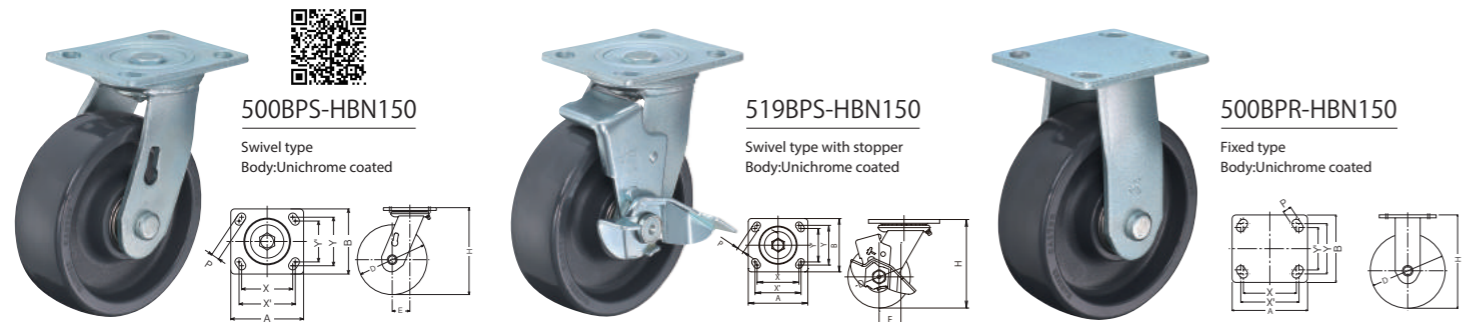

Product Code			Load Capacity 1pc(daN)	Wheel Composition	Overall Height Hmm	Top Plate A×B mm	Fitting Pitch X×Y mm (X'×Y') mm	Fastening hole dia. Pmm	Tread width mm
Model No.	Wheel	Size (mm)							
500 BPS 519 BPS 500 BPR	- HBN	150	250	Solid Elastomer Wheel with Ball bearing	187	114×102	80×76 (88×64)	13	50

※Please consult our sales office for details.

HAMMER CASTER SALES

T O K Y O

Zip 105-0004
6-5-4, Shinbashi, Minatoku, Tokyo
TEL 03-3434-2941 FAX 03-3434-2615

O S A K A

Zip 578-0964
10-35, Shinjonishi, Higashiosakashi, Osaka
TEL 06-6746-3930 FAX 06-6746-3943

SHIZUOKA

Zip 422-8036
1-3-22, Shikichi, Surugaku, Shizuoka
TEL 054-237-5409 FAX 054-237-0756

OKAYAMA

Zip 700-0922
7-23, Higashifurumatsu-minamimachi, Kitaku, Okayama
TEL 086-226-2660 FAX 086-226-2664

N A G O Y A

Zip 462-0038
1-45, Chigonomiyadori, Kitaku, Nagoya
TEL 052-915-1020 FAX 052-911-0420

HIROSHIMA

Zip 733-0842
5-20-2, Iguchi, Nishiku, Hiroshima
TEL 082-277-2935 FAX 082-277-2936

KANAZAWA

Zip 921-8001
3-15, Takabatake, Kanazawa
TEL 076-292-0315 FAX 076-292-0313

FUKUOKA

Zip 812-0006
1-26-16, Kamimuta, Hakataku, Fukuoka
TEL 092-472-5655 FAX 092-474-2736

A Starting Difference



HBN

Light handling & Smooth traveling
Elastomer Wheel

Labor saving by stress-free handling.



HBN

Solid Elastomer Wheel
with Ball bearing

The special elastomer wheel gives excellent starting and swiveling performance.
The service life is extended by heat treated steel body.

Wheel Characteristics

- Excellently resistant to cutting oil and chemical.※1
- No floor marking at jump start or sudden stop.
- Installed ball bearing at wheel bore, increased durability.
- Battery saving for AGV by light driving force.※2



※1 Please consult our sales offices for the anti-chemical property in detail.
※2 Please specify "Bolt Lock type" when installing to AGV for safety.

■ Wheel comparison in tractive force between RB(rubber) and HBN(special elastomer)

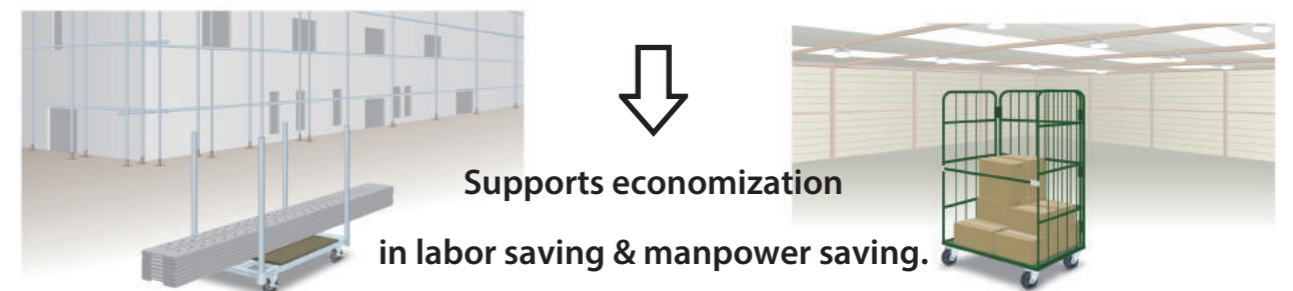
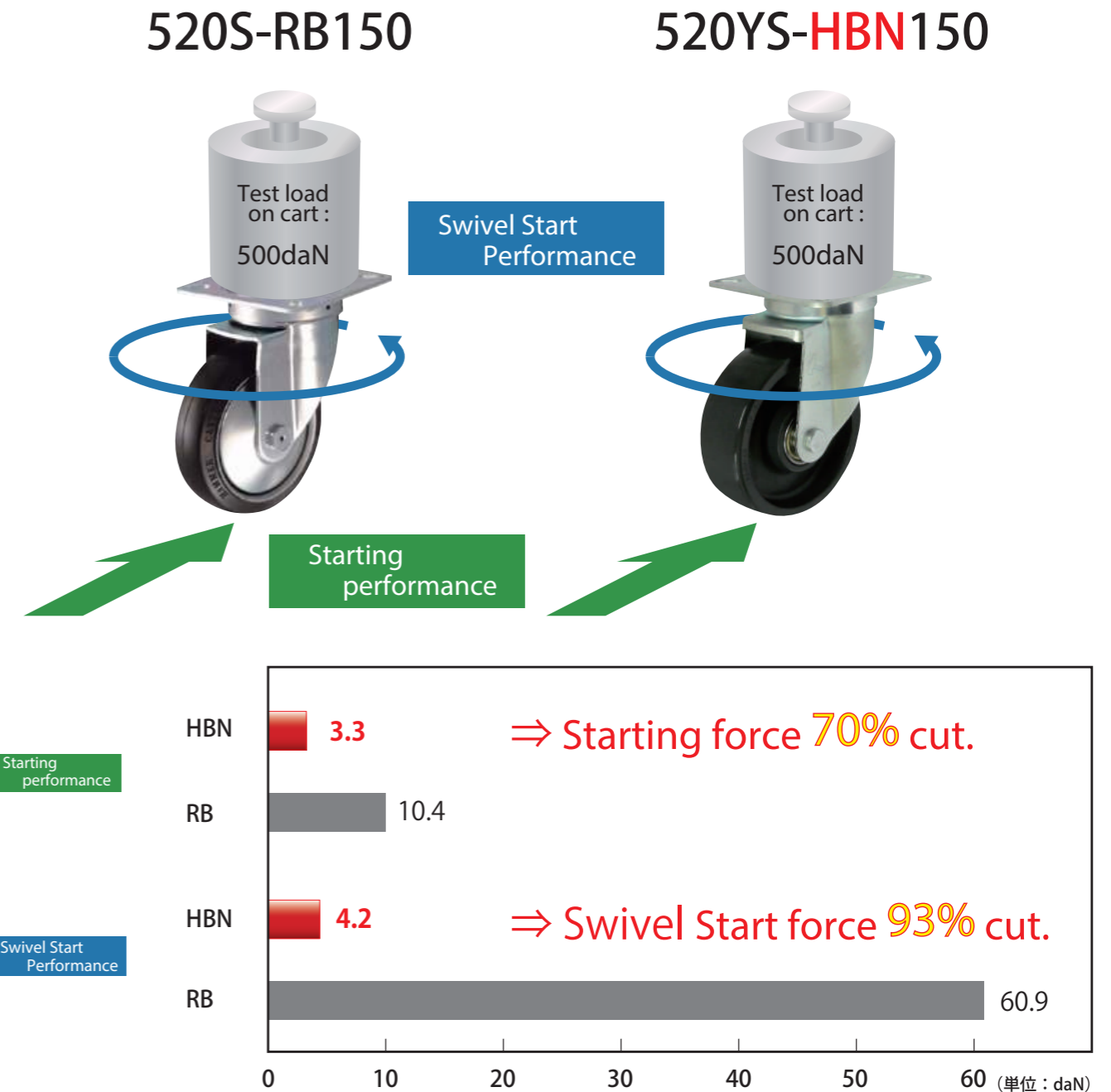

■ What is "Elastomer (TPE)" ?



Elastomer material combines the superior properties of elastic rubber and plastics, which is easy to mold and recycle, and are expected to play an active role in a wide range of industrial fields.